

HOBART701 S Ridge Avenue, Troy, OH 45374
1-888-4HOBART • www.hobartcorp.com**C44A/C44AW
DISHWASHER****HOBART****STANDARD FEATURES**

- 202 racks per hour – C44A
- 126 racks per hour – C44AW
- Opti-RinSe™ system
- Ball detent clutch conveyor drive mechanism
- Top mounted controls
- Stainless steel anti-clogging wash arms
- Stainless front panel, frame and legs
- Automatic fill
- Auto-timer
- Scrap screen and deep basket system
- Stainless steel self-draining pump and impeller
- Fixed pump intake screen
- Door actuated drain closure
- Door interlock switch on all doors
- Vent fan control
- Convertible hot water or low temp final rinse
- Booster heater control

DIRECTION OF OPERATION

- Right to Left
- Left to Right

VOLTAGE

- 208-240/60/1
- 208-240/60/3
- 480/60/3

OPTIONS AT EXTRA COST

- Stainless steel pressureless 15 kw or 30 kw booster heater
- Single point electrical connection (does not include booster heater)
- 6" higher than standard chamber
- Conveyor dwell
- Side loader
- Blower-dryer

MODEL

- C44A – Dishwasher
- C44AW – Dishwasher (12% lower water use)

ACCESSORIES

- Stainless steel vent hoods
- Direct drive unloader
- Side loader

Specifications, Details and Dimensions on Inside and Back.

**C44A/C44AW DISHWASHER**

C44A/C44AW DISHWASHER

HOBART

701 S Ridge Avenue, Troy, OH 45374
1-888-4HOBART • www.hobartcorp.com

C-LINE DISHWASHER NOW STANDARD WITH MORE PRODUCTIVE FEATURES THAN EVER . . .

Inside and out the C-Line Hobart dishwashers are packed with standard components and design innovations that make them the biggest value in the dishwasher industry.

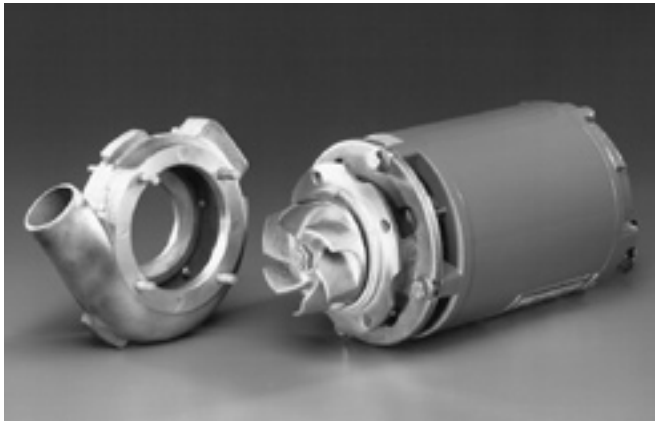

Stainless Steel Self-Draining Pump and Impeller. Pump and impeller are stainless steel for maximum durability. A fixed pump intake screen prevents debris from entering into the pump.



Wash Arms. Computer-designed wash arms resist clogging, easily removed for cleaning (C-44A shown).



Opti-RinSe™. Hobart's exclusive patent pending Opti-RinSe™ significantly reduces operating cost by reducing rinse water and the energy required to heat the water. The unique spray pattern uses large droplets to more efficiently sanitize the ware.



Lift-Out Scrap Basket. Screen design sheds soil more easily than flat screens, reduces frequency of cleaning — easy to empty large soil particles . . . Just lift out scrap basket under screens.

OPTIONAL BOOSTER HEATER



Built-in Pressureless Stainless Steel Booster Heater. Interwired and interplumbed. Saves on installation and saves floor space. Simplifies operation with just one switch to power dishmachine and booster.

OTHER STANDARD FEATURES . . .

- **Low-Temp Convertibility In Field.** Order your C-Line with hot water sanitizing or energy-saving low temperature chemical sanitizing — then, if requirements change, convert from one mode to the other in the field. An exclusive feature — standard from Hobart.
- **Auto-Fill.** One button automatic fill ensures optimum tank level, and the simplest operation.
- **Auto-Timer.** Automatically activates the warewasher when a rack enters the machine, and after the last rack has passed, shuts off the pump and conveyor while maintaining tank heat temperature. Extends machine life, requires less operator attention and promotes significant energy savings.
- **Door Actuated Drain Closure.** Closing the door automatically actuates drain closure, eliminates extra manual steps, insures that closure is in the correct position.
- **Vent Fan Control and Booster Heater Control.** Allows for interconnection to dishwasher.



701 S Ridge Avenue, Troy, OH 45374
1-888-4HOBART • www.hobartcorp.com

C44A/C44AW DISHWASHER

AVAILABLE OPTIONS AND ACCESSORIES . . .

Flexibility is synonymous with Hobart C-Line dishwashers. If your operation demands a dishwasher with a vent hood, an extended hood . . . a recirculating prewash, just specify the combination of options that suit your needs.



Side Loader. Save up to 20 square feet in the dishroom layout with an optional C-Line Side Loader. Racks are indexed 90° into the dishwasher automatically – a feature that cuts space and reduces labor dramatically. Your dishroom team will appreciate this feature.



Extended Hood

Vent Hood

C-Line Dishwashers are available with vent hoods or extended hoods, each with vent stack and locking-type damper, and both designed to fit either end of the dishwasher.

OTHER AVAILABLE OPTIONS . . .

Condenser, blower-dryer, conveyor dwell, steam booster heater, and a single-point electrical connection for electric heat machines.

	C44A	C44AW
Machine Ratings (Mechanical)		
Racks per hour (19¼" x 19¼")	202	126
Conveyor Speed - feet per minute	5.6 max.	3.5 max.
Dishes per Hour (Average 25 per rack)	5,025	3,150
Glasses per Hour (Average 45 per rack)	9,045	5,670
Floor Space - Table to Table (Inches)	← 44 →	
Overall Dimensions - H x W x D (Inches)	← 70¼ x 45¼ x 30¼ →	
Motor H.P.	← 2 →	
Conveyor Drive H.P.	← ½ →	
Blower-Dryer - Motor H.P. (if used)	← 2 →	
Electric Blower Dryer		
Heating Coils (if used)	← 42.0 KW →	
Blower-Dryer - Based on 20 PSI		
Flowing Steam if used (25 PSIG MAX.)	← 110 →	
Number of Tanks	← 1 →	
Tank Capacity - Gallons	← 23.0 →	
Pump Capacity - Gallons per Minute - Weir Test	151	104
Heating Equipment -		
(For keeping power wash hot)		
Gas Burners (with Natural Gas) - BTU per hr.	← 78,000 →	
Steam Injectors	← Regulated ¾" →	
Electric Heating Unit - Size Used	← Regulated 15 KW →	
Optional Booster Heater / Final Rinse	← 15 KW / 30 KW →	
Rinse - Minutes operated during hour of maximum operation	← 60 →	
Final Rinse Flow - Gals. per min.		
At 15 PSI Flow Pressure	1.83	1.19
At 20 PSI Flow Pressure	2.13	1.36
Final Rinse Flow - Gals. per hr. - MAXIMUM		
At 15 PSI Flow Pressure	110	71
At 20 PSI Flow Pressure	128	82
Rinse 20 PSI Flow Pressure Gal./Rack	Hot Water Sanitizing - Chemical Sanitizing ← .64 - 180°F - .64 - 140°F .65 - 180°F - .65 - 140°F →	
Steam Consumption -		
Pounds per hr. - MAXIMUM		
Approx. 30 lbs. per hr. = 1 boiler H.P. (BHP) Dishwasher, based on 20 PSI steam and on customersupplying final rinse water at 180°F maximum	← 65 →	
Steam Booster, if used on 20 PSI steam - 20 PSI water flowing - 130°F entering water raised to 180°F min.	60	37
Exhaust Requirements -		
Cubic Feet per minute		
Entrance End	← 200 →	
Discharge End	← 400 →	
Discharge end w/Blower Dryer	← 1400 →	
Peak Rate of Drain Flow - Gallons per minute. (Initial rate with full tank)	← 38 →	
Shipping Weight Crated - Approximate lbs.	← 613 →	

C44A/C44AW DISHWASHER



701 S Ridge Avenue, Troy, OH 45374
1-888-4HOBART • www.hobartcorp.com

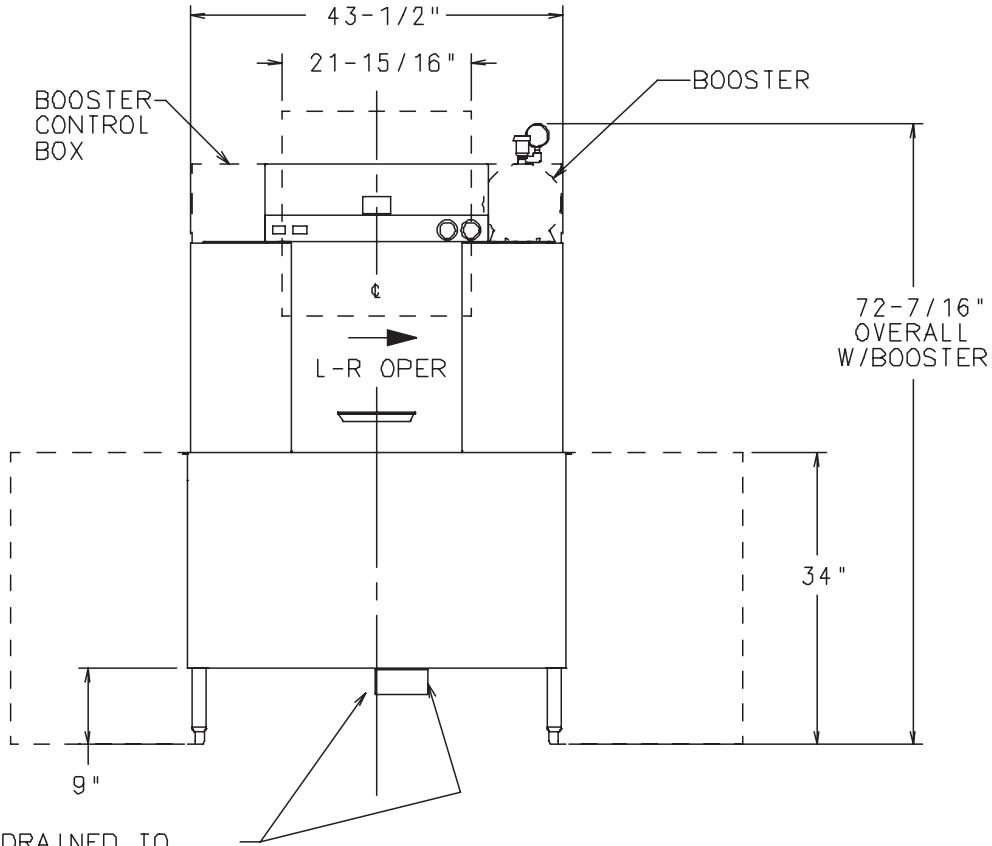

MAY BE DRAINED TO EITHER SIDE OF VALVE, PLUG OPPOSITE SIDE.

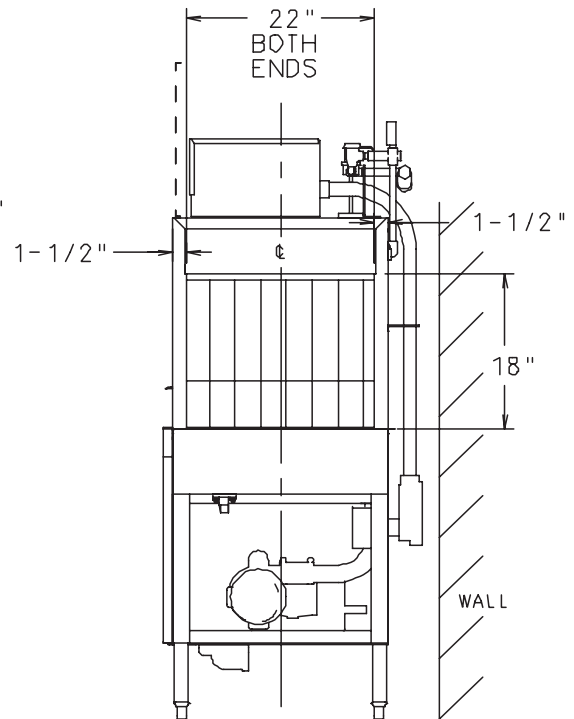
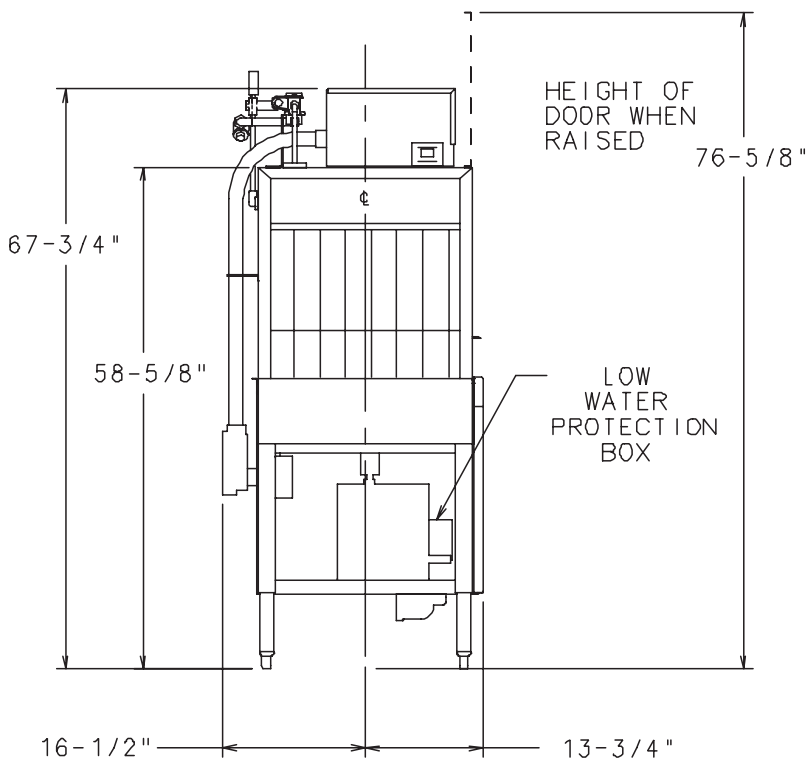



701 S Ridge Avenue, Troy, OH 45374
1-888-4HOBART • www.hobartcorp.com

C44A/C44AW DISHWASHER

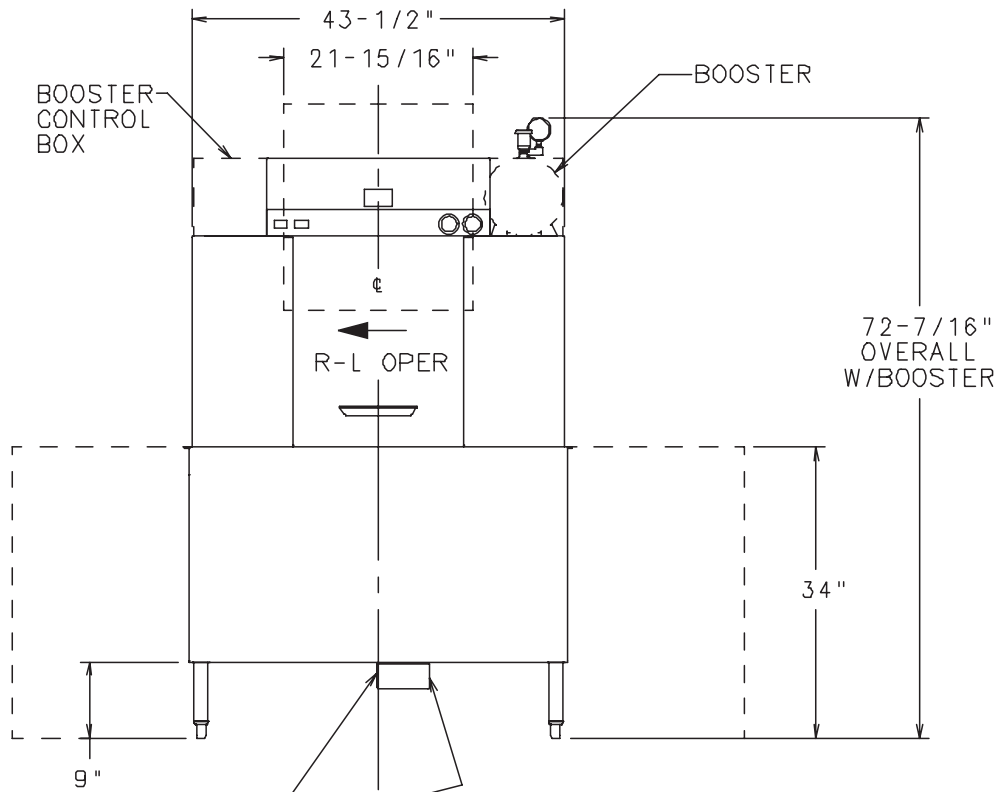

MAY BE DRAINED TO EITHER SIDE OF VALVE, PLUG OPPOSITE SIDE.

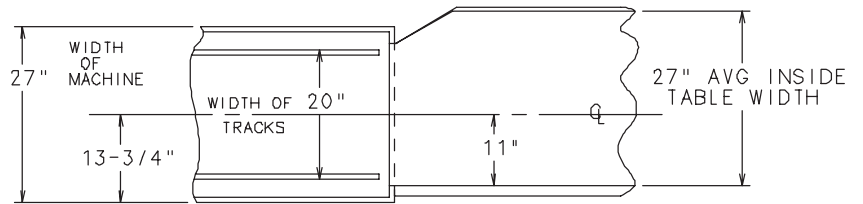

SUGGESTED TRACK AND TABLE LAYOUT

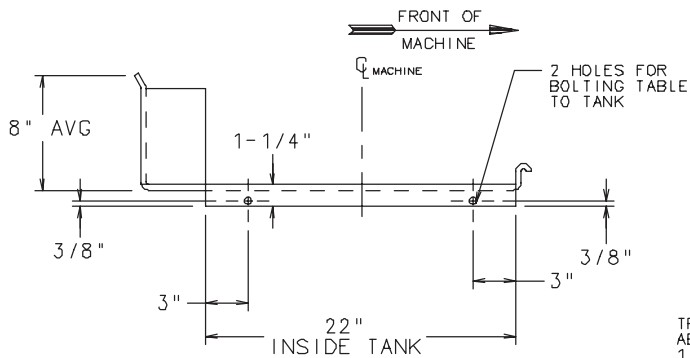

VIEW SHOWING HOLE LOCATIONS IN TURNED DOWN PORTION OF TABLE

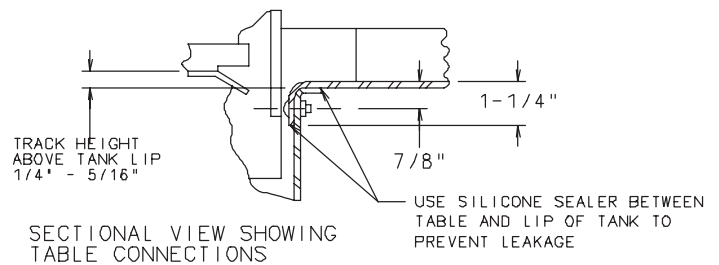

SECTIONAL VIEW SHOWING TABLE CONNECTIONS

C44A/C44AW ELECTRIC L-R



701 S Ridge Avenue, Troy, OH 45374
1-888-4HOBART • www.hobartcorp.com

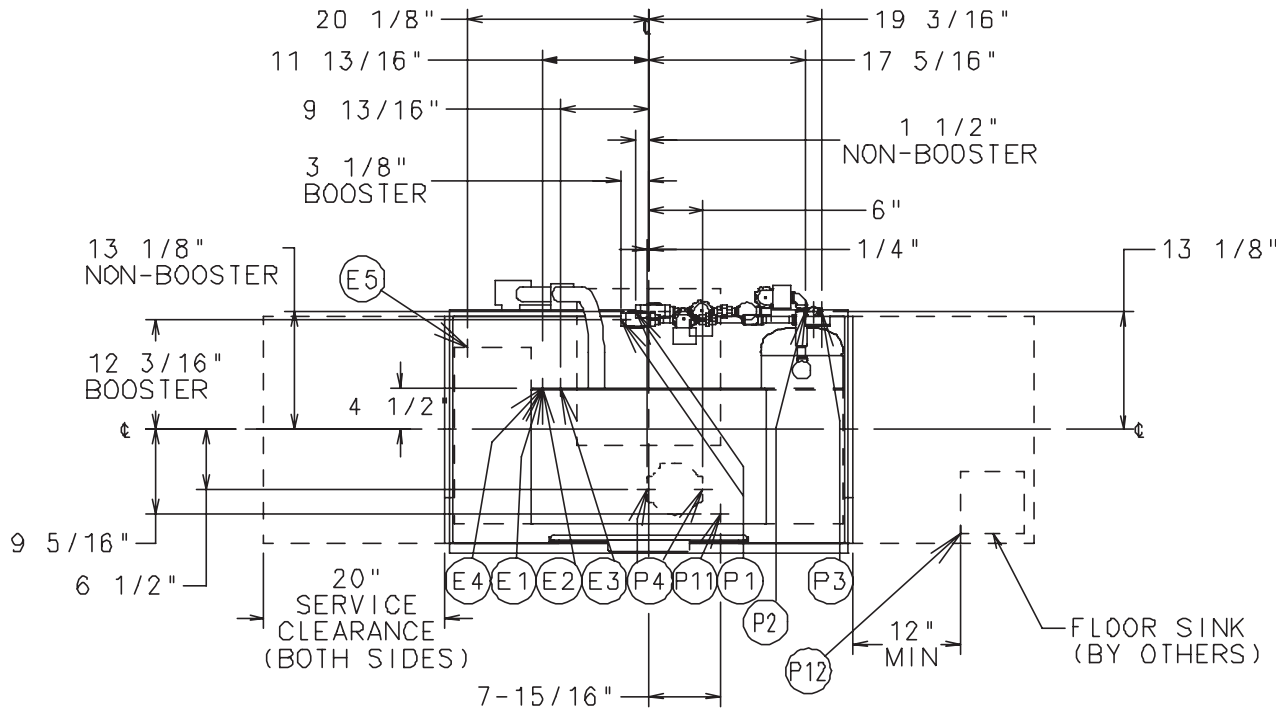

MODEL: C-44A/C-44AW
L-R OPERATION
D-435274/D-328072
REV. K/REV. J

PLUMBING NOTES:

WATER HAMMER ARRESTOR (MEETING ASSE-1010 STANDARD OR EQUIVALENT) TO BE SUPPLIED (BY OTHERS) IN COMMON WATER SUPPLY LINE AT SERVICE CONNECTION.
RECOMMENDED WATER HARDNESS TO BE 4-6 GRAINS FOR BEST RESULTS.
RECOMMENDED BUILDING FLOWING WATER PRESSURE TO THE DISHWASHER IS 20-25 PSI. IF PRESSURES HIGHER THAN 25 PSI ARE PRESENT, A PRESSURE REGULATING VALVE WITH INTERNAL THERMAL EXPANSION BY PASS, MUST BE SUPPLIED (BY OTHERS) IN THE WATER LINE TO THE DISHWASHER.
FOR CONVENIENCE WHEN CLEANING, WATER TAP SHOULD BE INSTALLED NEAR MACHINE WITH HEAVY DUTY HOSE AND SQUEEZE VALVE.
DISHWASHER MUST BE INSTALLED AND OPERATED ONLY WITH CHEMICAL SANITIZING FEEDER THAT IS LISTED BY NSF INTERNATIONAL.
WHEN REQUIRED, INSTALL FLOOR SINK OUTSIDE THE PERIMETER OF THE DISHWASHER

MISCELLANEOUS NOTES:

WHEN VENT HOODS OR EXTENDED HOODS ARE ORDERED, REFER TO C-LINE VENTS AND HOODS SPECIFICATION SHEET (FORM F-7841) FOR DETAILS AND CONNECTIONS.
EXHAUST REQUIREMENTS: 200 CFM ENTRANCE END
400 CFM EXIT END.
ALL DIMENSIONS TAKEN FROM FLOOR LINE MAY BE INCREASED APPROXIMATELY 3/4" OR DECREASED 1/2".
44" INSIDE TANK (AT TABLE CONNECTION)
43-25/32" TABLE TO TABLE.
NET WEIGHT OF MACHINE: 563 LBS.
DOMESTIC SHIPPING WEIGHT: 613 LBS.

WARNING

ELECTRICAL AND GROUNDING CONNECTIONS MUST COMPLY WITH THE APPLICABLE PORTIONS OF THE NATIONAL ELECTRICAL CODE AND/OR OTHER LOCAL ELECTRICAL CODES.

PLUMBING CONNECTIONS MUST COMPLY WITH APPLICABLE SANITARY, SAFETY, AND PLUMBING CODES.

CAUTION: CERTAIN MATERIALS INCLUDING SILVER, ALUMINUM, AND PEWTER ARE ATTACKED BY SODIUM HYPOCHLORITE (LIQUID BLEACH).

SEPARATE SERVICE CONNECTION FOR ELEC. HEAT

ELEC. HEAT 15 KW (WASH)			
ELEC. SPECS.	RATED AMPS	MINIMUM SUPPLY CIRCUIT CONDUCTOR AMPACITY	MAXIMUM PROTECTIVE DEVICE
208/60/1	77.9	100	100
240/60/1	74.1	100	100
208/60/3	44.9	60	60
240/60/3	42.8	60	60
480/60/3	21.4	30	30

MOTORS: 1/6 HP CONVEYOR
2 HP WASH

ELECTRIC SPECS.	RATED AMPS	MINIMUM SUPPLY CIRCUIT CONDUCTOR AMPACITY	MAXIMUM PROTECTIVE DEVICE
208-240/60/1	15.5	20	20
208-240/60/3	11.1	15	15
480/60/3	6.8	15	15

SINGLE POINT ELECTRICAL CONNECTION (3 PH ONLY) MOTORS AND ELECTRIC TANK HEAT

ELECTRIC SPECS.	RATED AMPS	MINIMUM SUPPLY CIRCUIT CONDUCTOR AMPACITY	MAXIMUM PROTECTIVE DEVICE
208/60/3	56.0	70	70
240/60/3	53.9	70	70
480/60/3	28.2	40	40



701 S Ridge Avenue, Troy, OH 45374
1-888-4HOBART • www.hobartcorp.com

C44A/C44AW ELECTRIC R-L

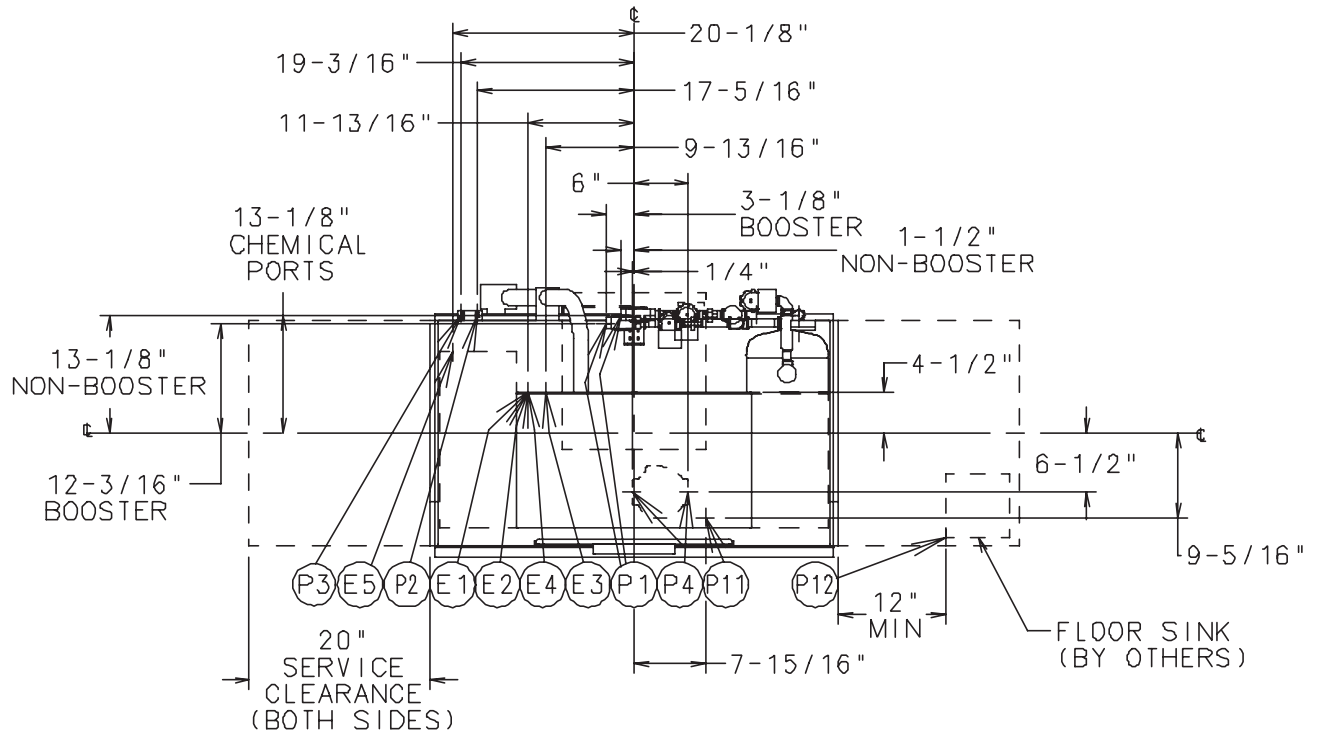

MODEL: C-44A/C-44AW
R-L OPERATION
D-435273/D-328071
REV. K/REV. J

BOOSTER HEAT 15 KW			
ELEC. SPECS.	RATED AMPS	MINIMUM SUPPLY CIRCUIT CONDUCTOR AMPACITY	MAXIMUM PROTECTIVE DEVICE
200-240/50/3	40.1	50	50
380-415/50/3	26.6	30	30
200/50/3	43.3	60	60
208-240/60/3	40.1	50	50
208/60/3	45.0	60	60
240/60/3	40.1	50	50
380/60/3	21.3	30	30
380-415/60/3	23.2	30	30
480/60/3	20.0	25	25
600/60/3	13.5	20	20

BOOSTER HEAT 30 KW			
ELEC. SPECS.	RATED AMPS	MINIMUM SUPPLY CIRCUIT CONDUCTOR AMPACITY	MAXIMUM PROTECTIVE DEVICE
200-240/50/3	80.2	90	90
380-415/50/3	53.2	60	60
200/50/3	80.8	90	90
208-240/60/3	80.2	90	90
208/60/3	83.9	90	90
240/60/3	80.2	90	90
380/60/3	42.5	60	60
380-415/60/3	46.4	60	60
480/60/3	40.1	50	50
600/60/3	33.7	40	40

CONNECTION INFORMATION (*AFF - ABOVE FINISHED FLOOR)

LEGEND

- E1 ELECTRICAL CONNECTION (EXCEPT ELECTRIC HEAT): 3/4" CONDUIT HOLE, 65-1/2" AFF.
- E2 ELECTRIC HEAT: 15,000 WATTS, 1" CONDUIT HOLE, 63-5/8" AFF.
- E3 ELECTRICAL CONNECTION-DETERGENT/RINSE AGENT/SANITIZER FEEDERS: 1/2" CONDUIT HOLE 65-1/2" AFF
- E4 SINGLE POINT ELECTRICAL CONNECTION: (ELECTRIC HEAT ONLY), 1" CONDUIT HOLE, 63-5/8" AFF
- E5 ELECTRICAL CONNECTION: BOOSTER. 15KW/30KW, 1-1/4" CONDUIT HOLE, 63-5/8" AFF.
- P1 COMMON WATER CONNECTION: 180°F WATER MIN. (HIGH TEMP), 140°F WATER MIN. (LOW TEMP), 3/4" FPT, 63-7/8" AFF.
- P2 SANITIZER FEEDER: REMOVE 1/8" NPT PIPE PLUG TO ACCESS TAPPED HOLE, 1/8" NPT, 54 9/16" AFF (LOW TEMP.)
- P3 RINSE AGENT FEEDER: 1/8" NPT, REMOVE 1/8" NPT PIPE PLUG TO ACCESS TAPPED HOLE, 54-9/16" AFF (LOW TEMP.)
- P4 DRAIN: 2" FPT, 7-5/16" AFF TWO CONNECTIONS.
- P11 DETERGENT PROBE SENSOR: REMOVE CAP AND STUD ASSEMBLY TO ACCESS 7/8" HOLE, 12" AFF
- P12 INDIRECT DRAIN-FLOOR SINK: BY OTHERS, 0" AFF.

C44A/C44AW GAS L-R



701 S Ridge Avenue, Troy, OH 45374
1-888-4HOBART • www.hobartcorp.com

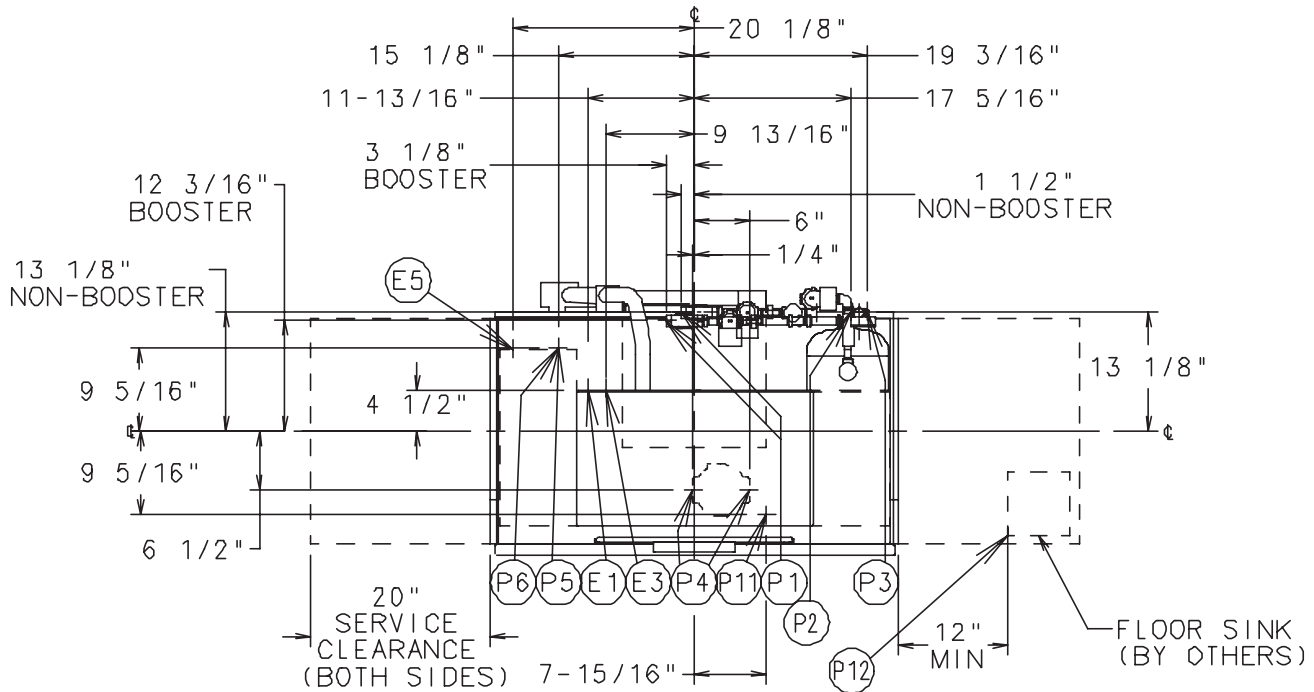

GAS HEATED DISHWASHERS

FOR NATURAL GAS, PRESSURE TO THE BURNER (CUSTOMER CONNECTION) SHOULD NOT EXCEED 7" W.C.

FOR LP GAS, PRESSURE TO THE BURNER (CUSTOMER CONNECTION) SHOULD NOT EXCEED 11" W.C.

IF GAS PRESSURE IS HIGHER THAN 7" (NAT) OR 11" (LP) W.C., A PRESSURE REGULATING VALVE MUST BE INSTALLED (BY OTHERS) IN THE GAS LINE TO THE DISHWASHER.

GAS HEAT BTU INPUT - 78,000 NATURAL
78,000 LP

WHEN GAS TANK HEAT IS SPECIFIED, GAS EXHAUST VENTING MUST BE INSTALLED ACCORDING TO LOCAL CODE. DO NOT CONNECT FLUE TO POWER VENT.

PLUMBING NOTES:

WATER HAMMER ARRESTOR (MEETING ASSE-1010 STANDARD OR EQUIVALENT) TO BE SUPPLIED (BY OTHERS) IN COMMON WATER SUPPLY LINE AT SERVICE CONNECTION.

RECOMMENDED WATER HARDNESS TO BE 4-6 GRAINS FOR BEST RESULTS.

RECOMMENDED BUILDING FLOWING WATER PRESSURE TO THE DISHWASHER IS 20 PSI (15 PSI MIN - 25 PSI MAX). IF PRESSURES HIGHER THAN 25 PSI ARE PRESENT, A PRESSURE REGULATING VALVE WITH INTERNAL THERMAL EXPANSION BY PASS, MUST BE SUPPLIED (BY OTHERS) IN THE WATER LINE TO THE DISHWASHER.

FOR CONVENIENCE WHEN CLEANING, WATER TAP SHOULD BE INSTALLED NEAR MACHINE WITH HEAVY DUTY HOSE AND SQUEEZE VALVE.

DISHWASHER MUST BE INSTALLED AND OPERATED ONLY WITH CHEMICAL SANITIZING FEEDER THAT IS LISTED BY NSF INTERNATIONAL.

WHEN REQUIRED, INSTALL FLOOR SINK OUTSIDE THE PERIMETER OF THE DISHWASHER

MISCELLANEOUS NOTES:

WHEN VENT HOODS OR EXTENDED HOODS ARE ORDERED, REFER TO C-LINE VENTS AND HOODS SPECIFICATION SHEET (FORM F-7841) FOR DETAILS AND CONNECTIONS.

EXHAUST REQUIREMENTS: 200 CFM ENTRANCE END
400 CFM EXIT END

ALL DIMENSIONS TAKEN FROM FLOOR LINE MAY BE INCREASED APPROXIMATELY 3/4" OR DECREASED 1/2".

44" INSIDE TANK (AT TABLE CONNECTION)
43-25/32" TABLE TO TABLE.

WARNING

ELECTRICAL AND GROUNDING CONNECTIONS MUST COMPLY WITH THE APPLICABLE PORTIONS OF THE NATIONAL ELECTRICAL CODE AND/OR OTHER LOCAL ELECTRICAL CODES.

PLUMBING CONNECTIONS MUST COMPLY WITH APPLICABLE SANITARY, SAFETY, AND PLUMBING CODES.

CAUTION: CERTAIN MATERIALS INCLUDING SILVER, ALUMINUM, AND PEWTER ARE ATTACKED BY SODIUM HYPOCHLORITE (LIQUID BLEACH).

MOTORS: 1/6 HP CONVEYOR
2 HP WASH

ELECTRIC SPECS.	RATED AMPS	MINIMUM SUPPLY CIRCUIT CONDUCTOR AMPACITY	MAXIMUM PROTECTIVE DEVICE
208-240/60/1	15.5	20	20
208-240/60/3	11.1	15	15
480/60/3	6.8	15	15



701 S Ridge Avenue, Troy, OH 45374
1-888-4HOBART • www.hobartcorp.com

C44A/C44AW GAS R-L

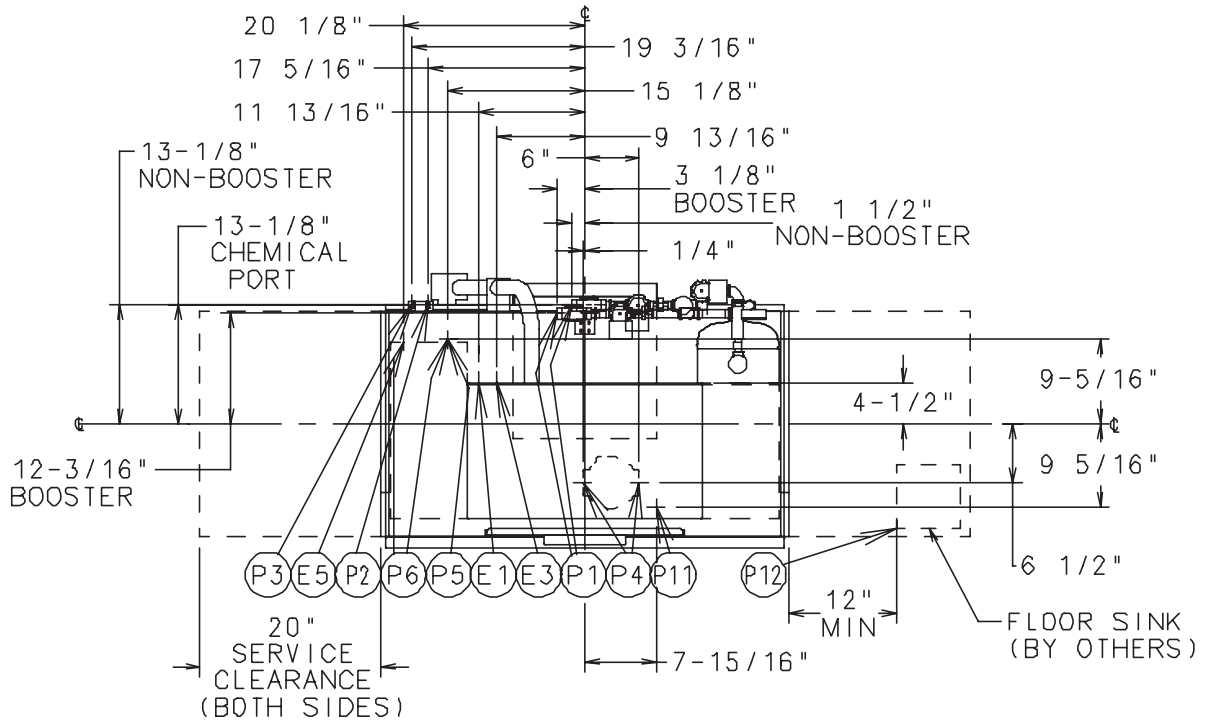

BOOSTER HEAT 15 KW			
ELEC. SPECS.	RATED AMPS	MINIMUM SUPPLY CIRCUIT CONDUCTOR AMPACITY	MAXIMUM PROTECTIVE DEVICE
200-240/50/3	40.1	50	50
380-415/50/3	26.6	30	30
200/50/3	43.3	60	60
208-240/60/3	40.1	50	50
208/60/3	45.0	60	60
240/60/3	40.1	50	50
380/60/3	21.3	30	30
380-415/60/3	23.2	30	30
480/60/3	20.0	25	25
600/60/3	13.5	20	20

BOOSTER HEAT 30 KW			
ELEC. SPECS.	RATED AMPS	MINIMUM SUPPLY CIRCUIT CONDUCTOR AMPACITY	MAXIMUM PROTECTIVE DEVICE
200-240/50/3	80.2	90	90
380-415/50/3	53.2	60	60
200/50/3	80.8	90	90
208-240/60/3	80.2	90	90
208/60/3	83.9	90	90
240/60/3	80.2	90	90
380/60/3	42.5	60	60
380-415/60/3	46.4	60	60
480/60/3	40.1	50	50
600/60/3	33.7	40	40

CONNECTION INFORMATION (*AFF - ABOVE FINISHED FLOOR)

LEGEND

- E1 ELECTRICAL CONNECTION (EXCEPT ELECTRIC HEAT): 3/4" CONDUIT HOLE, 65-1/2" AFF.
- E3 ELECTRIC CONNECTION-DETERGENT/RINSE AGENT/SANITIZER FEEDERS: 1/2" CONDUIT HOLE 65-1/2" AFF
- E5 ELECTRIC CONNECTION: BOOSTER. 15KW/30KW, 1-1/4" CONDUIT HOLE, 63-5/8" AFF.
- P1 COMMON WATER CONNECTION: 180°F WATER MIN. (HIGH TEMP), 140°F WATER MIN. (LOW TEMP), 3/4" FPT, 63-7/8" AFF.
- P2 SANITIZER FEEDER: REMOVE 1/8" NPT PIPE PLUG TO ACCESS TAPPED HOLE, 1/8" NPT, 54-9/16" AFF (LOW TEMP.)
- P3 RINSE AGENT FEEDER: 1/8" NPT, REMOVE 1/8" NPT PIPE PLUG TO ACCESS TAPPED HOLE, 54-9/16" AFF. (54-9/16" AFF LOW TEMP.)
- P4 DRAIN: 2" FPT, 7-5/16" AFF TWO CONNECTIONS.
- P5 GAS CONNECTION - NAT. (WHEN ORDERED): 1/2" FPT, 8-5/16" AFF.
- P6 GAS CONNECTION - L.P. (WHEN ORDERED): 1/2" FPT, 8-5/16" AFF.
- P11 DETERGENT PROBE SENSOR: REMOVE CAP AND STUD ASSEMBLY TO ACCESS 7/8" HOLE, 12" AFF
- P12 INDIRECT DRAIN-FLOOR SINK: BY OTHERS, 0" AFF.

C44A/C44AW STEAM L-R



701 S Ridge Avenue, Troy, OH 45374
1-888-4HOBART • www.hobartcorp.com

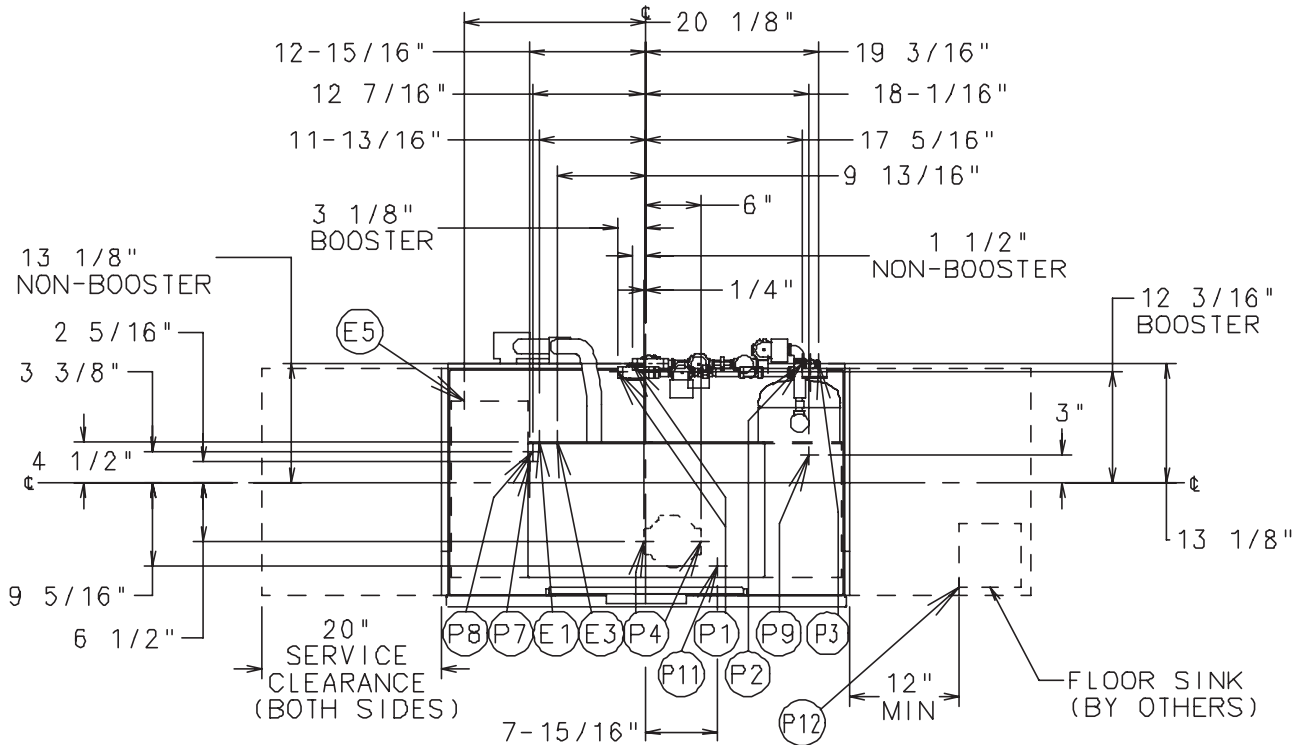

PLUMBING NOTES:

- WATER HAMMER ARRESTOR (MEETING ASSE-1010 STANDARD OR EQUIVALENT) TO BE SUPPLIED (BY OTHERS) IN COMMON WATER SUPPLY LINE AT SERVICE CONNECTION.
- RECOMMENDED WATER HARDNESS TO BE 4-6 GRAINS FOR BEST RESULTS.
- RECOMMENDED BUILDING FLOWING WATER PRESSURE TO THE DISHWASHER IS 20-25 PSI. IF PRESSURES HIGHER THAN 25 PSI ARE PRESENT, A PRESSURE REGULATING VALVE WITH INTERNAL THERMAL EXPANSION BY PASS, MUST BE SUPPLIED (BY OTHERS) IN THE WATER LINE TO THE DISHWASHER.
- FOR CONVENIENCE WHEN CLEANING, WATER TAP SHOULD BE INSTALLED NEAR MACHINE WITH HEAVY DUTY HOSE AND SQUEEZE VALVE.
- DISHWASHER MUST BE INSTALLED AND OPERATED ONLY WITH CHEMICAL SANITIZING FEEDER THAT IS LISTED BY NSF INTERNATIONAL.
- FLOWING STEAM PRESSURES ABOVE 50 PSI MUST HAVE A PRESSURE REGULATOR (NOT SUPPLIED) INSTALLED IN THE STEAM LINE.
- SHUT OFF VALVE MUST BE SUPPLIED (BY OTHERS) IN THE STEAM LINE TO THE DISHWASHER.
- WHEN REQUIRED, INSTALL FLOOR SINK OUTSIDE THE PERIMETER OF THE DISHWASHER

MISCELLANEOUS NOTES:

- WHEN VENT HOODS OR EXTENDED HOODS ARE ORDERED, REFER TO C-LINE VENTS AND HOODS SPECIFICATION SHEET (FORM F-7841) FOR DETAILS AND CONNECTIONS.
- EXHAUST REQUIREMENTS: 200 CFM ENTRANCE END
400 CFM EXIT END.
- ALL DIMENSIONS TAKEN FROM FLOOR LINE MAY BE INCREASED APPROXIMATELY 3/4" OR DECREASED 1/2".
- 44" INSIDE TANK (AT TABLE CONNECTION)
- 43-25/32" TABLE TO TABLE.

WARNING

ELECTRICAL AND GROUNDING CONNECTIONS MUST COMPLY WITH THE APPLICABLE PORTIONS OF THE NATIONAL ELECTRICAL CODE AND/OR OTHER LOCAL ELECTRICAL CODES.

PLUMBING CONNECTIONS MUST COMPLY WITH APPLICABLE SANITARY, SAFETY, AND PLUMBING CODES.

CAUTION: CERTAIN MATERIALS INCLUDING SILVER, ALUMINUM, AND PEWTER ARE ATTACKED BY SODIUM HYPOCHLORITE (LIQUID BLEACH).

MOTORS: 1/6 HP CONVEYOR
2 HP WASH

ELECTRIC SPECS.	RATED AMPS	MINIMUM SUPPLY CIRCUIT CONDUCTOR AMPACITY	MAXIMUM PROTECTIVE DEVICE
208-240/60/1	15.5	20	20
208-240/60/3	11.1	15	15
480/60/3	6.8	15	15



701 S Ridge Avenue, Troy, OH 45374
1-888-4HOBART • www.hobartcorp.com

C44A/C44AW STEAM R-L

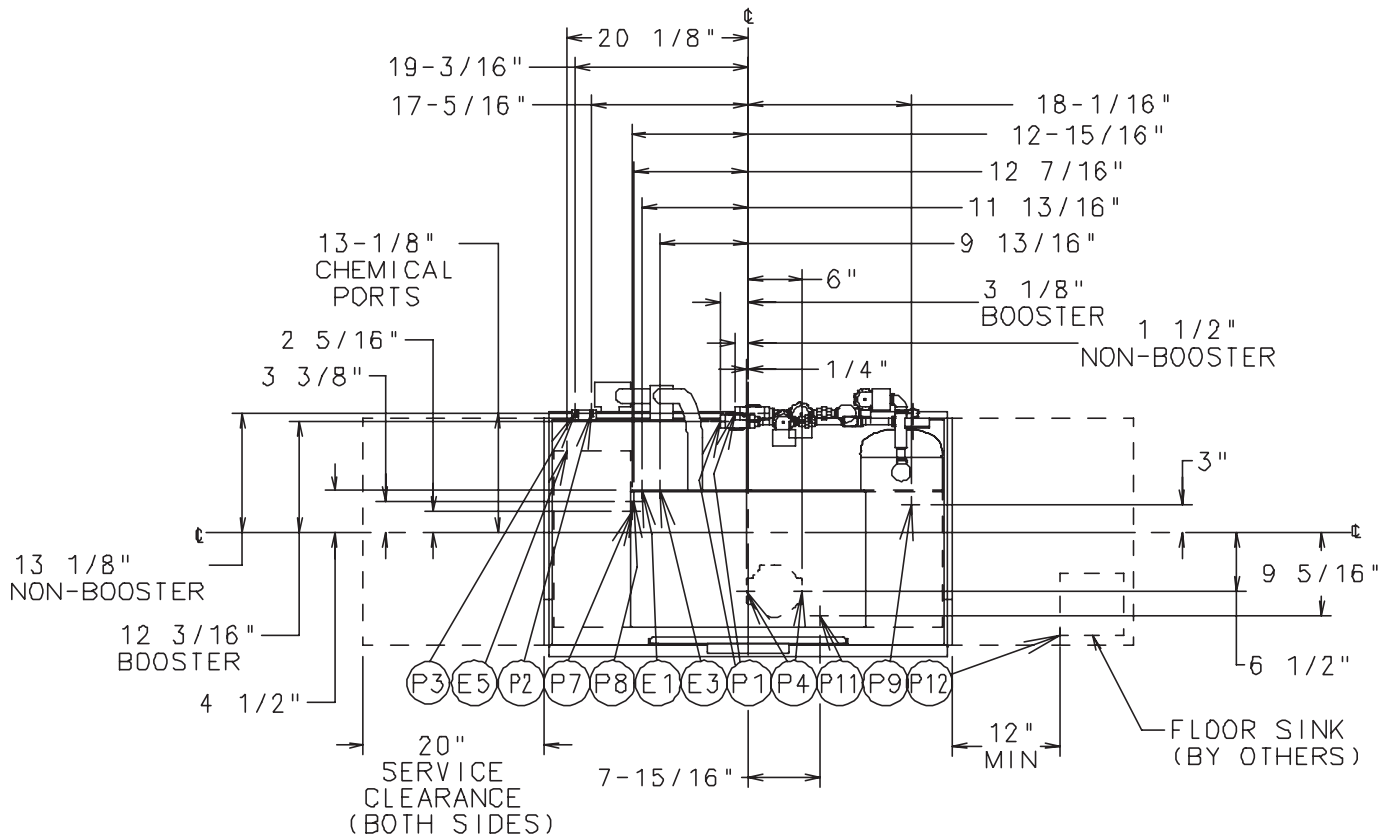

BOOSTER HEAT 15 KW			
ELEC. SPECS.	RATED AMPS	MINIMUM SUPPLY CIRCUIT CONDUCTOR AMPACITY	MAXIMUM PROTECTIVE DEVICE
200-240/50/3	40.1	50	50
380-415/50/3	26.6	30	30
200/50/3	43.3	60	60
208-240/60/3	40.1	50	50
208/60/3	45.0	60	60
240/60/3	40.1	50	50
380/60/3	21.3	30	30
380-415/60/3	23.2	30	30
480/60/3	20.0	25	25
600/60/3	13.5	20	20

BOOSTER HEAT 30 KW			
ELEC. SPECS.	RATED AMPS	MINIMUM SUPPLY CIRCUIT CONDUCTOR AMPACITY	MAXIMUM PROTECTIVE DEVICE
200-240/50/3	80.2	90	90
380-415/50/3	53.2	60	60
200/50/3	80.8	90	90
208-240/60/3	80.2	90	90
208/60/3	83.9	90	90
240/60/3	80.2	90	90
380/60/3	42.5	60	60
380-415/60/3	46.4	60	60
480/60/3	40.1	50	50
600/60/3	33.7	40	40

CONNECTION INFORMATION (*AFF - ABOVE FINISHED FLOOR)

LEGEND

- E1 ELECTRICAL CONNECTION (EXCEPT ELECTRIC HEAT): 3/4" CONDUIT HOLE, 65-1/2" AFF.
- E3 ELECTRIC CONNECTION-DETERGENT/RINSE AGENT/SANITIZER FEEDERS: 1/2" CONDUIT HOLE 65-1/2" AFF
- E5 ELECTRICAL CONNECTION: BOOSTER. 15KW/30KW, 1-1/4" CONDUIT HOLE, 63-5/8" AFF.
- P1 COMMON WATER CONNECTION: 180°F WATER MIN. (HIGH TEMP), 140°F WATER MIN. (LOW TEMP), 3/4" FPT, 63-7/8" AFF.
- P2 SANITIZER FEEDER: REMOVE 1/8" NPT PIPE PLUG TO ACCESS TAPPED HOLE, 1/8" NPT, 54-9/16" AFF (LOW TEMP.)
- P3 RINSE AGENT FEEDER: 1/8" NPT, REMOVE 1/8" NPT PIPE PLUG TO ACCESS TAPPED HOLE, 54-9/16" AFF. (54-9/16" AFF LOW TEMP.)
- P4 DRAIN: 2" FPT, 7-5/16" AFF TWO CONNECTIONS.
- P7 STEAM INJECTOR (WHEN ORDERED): 10 TO 25 PSI FLOWING, 50 PSI MAX., 3/4" FPT, 9-7/8" AFF.
- P8 STEAM COIL (WHEN ORDERED): 10 TO 25 PSI FLOWING, 50 PSI MAX., 3/4" FPT, 10-11/16" AFF.
- P9 CONDENSATE RETURN (STEAM COIL-WHEN ORDERED): 10 TO 50 PSI FLOWING, 3/4" FPT, 7-1/16" AFF, (BUCKET TYPE TRAP FURNISHED).
- P11 DETERGENT PROBE SENSOR: REMOVE CAP AND STUD ASSEMBLY TO ACCESS 7/8" HOLE, 12" AFF
- P12 INDIRECT DRAIN-FLOOR SINK: BY OTHERS, 0" AFF.

C44A/C44AW DISHWASHER

HOBART701 S Ridge Avenue, Troy, OH 45374
1-888-4HOBART • www.hobartcorp.com

SPECIFICATIONS: Meets requirements of A.S.S.E. Standard No. 1004.

DESIGN: Fully automatic, high-temperature single-tank, rack-type dishwasher with flexible strip curtains at ends of chamber and between wash and final rinse compartments. Large inspection door located in front of machine provides easy access to wash arms, rinse arms, rinse pan strainer, strainer basket, front and rear strainers, and pump intake screen. Door guided for ease of operation and long life. Design provides for changing of direction of operation in the field. Length of machine inside tank (at table connection) 44". Machine designed to clean and sanitize with hot water 160°F wash and 180°F (minimum) final rinse. Water hardness must be controlled to 4-6 gr. for best results. Automatic interlocks shut off pump and conveyor if door is opened when machine is in operation.

CONSTRUCTION: Tank and chamber constructed of #16 gauge stainless steel, arc-welded. Unitized, welded stainless steel tank, frame and stainless steel legs. Chamber, control box, door, and front trim panel are polished, satin finish.

PUMP: Recirculating stainless steel pump with stainless steel impeller and face seal with stainless steel metal components and ceramic seat. Readily removable motor/impeller assembly permits quick inspection. The pump is self-draining. All piping distributing water to the upper and lower wash arms is stainless steel tubing.

PUMP MOTOR: Built for Hobart: 2 horsepower, grease-packed ball bearings, splashproof, ventilated with manual resettable inherent overload protection. Available in electrical specifications of 208-240/60/1, 208-240/60/3, 480/60/3. Also available are 200-240/50/1, 200-240/50/3, 380-415/50/3, and 600/60/3, not submitted for UL Listing.

CONTROLS: A stainless steel control center with power "on/off" and "start/stop" switches is mounted on top of machine. Machine control circuitry components will be operated from a 120 volt control circuit transformer. Auto-timer is standard equipment. An "auto/manual" switch is located on the left side of control box for bypassing the auto-timer feature. Electrical components are completely wired with 105°C, 600V thermoplastic insulated wire with stranded conductors routed through Listed electrical conduit or covered wireway built into the front of the machine above tank water level.

CONVEYOR: Dual rack drive, with stainless steel pawls both sides of conveyor, designed to eliminate interference with wash and rinse spray patterns. Racks conveyed automatically through wash and rinse sections and onto clean dish table. Factory set overload mechanism on conveyor drive prevents damage to machine or racks, should movement of racks be obstructed. Rack tracks, conveyor structure, and drive units of stainless steel for 19 $\frac{3}{4}$ " x 19 $\frac{3}{4}$ " racks as standard. Conveyor speed: 5.6 FPM, C44A; 3.5 FPM, C44AW.

DRIVE MOTOR: Built for Hobart, $\frac{1}{8}$ horsepower gearmotor, ventilated with manual, resettable inherent overload protection. Available in electrical specifications of 208-240/60/1, 208-240/60/3, 480/60/3. Also available, but not submitted for UL Listing are 200-240/50/1, 200-240/50/3, and 380-415/50/3.

POWER WASH: Wash tank is equipped with upper and lower stainless steel wash arms with specially shaped nozzles having large openings and arranged to effectively direct water jets to all ware surfaces. Both upper and lower wash arms, along with wash arm end caps, are easily removable for cleaning without use of tools. Removable perforated stainless steel strainer pans support a deep perforated stainless steel basket. Basket and strainer pans (2) can be removed without lower wash arm removal.

FINAL RINSE: Stainless steel upper and lower rinse arms have single rows of nozzles. Rinse is automatically activated by racks in passing. Final rinse water line is equipped with vacuum breaker in downstream side of electrically operated solenoid valve in common piping system. Design provides for collection

and division of final rinse water after use to wash tank and drain. Rinse agent dispenser injection port provided in final rinse piping above chamber. Final rinse flow rate: 2.13 GPM, C44A; 1.36 GPM, C44AW.

Low Temp Final Rinse – Sanitizer agent (5.25% sodium hypochlorite – bleach) and rinse agent dispenser injection ports provided in final rinse piping above chamber. **Caution:** Certain materials, including silver, aluminum, and pewter are attacked by sodium hypochlorite (bleach) in the chemical sanitizing dishwasher mode of operation.

FILL: Fill water line is equipped with vacuum breaker on downstream side of electrically operated solenoid valve in common piping system, for automatic maintenance of tank level. Fill is interrupted whenever a door is opened.

DRAIN AND OVERFLOW: Large bell-type automatic overflow and drain valve controlled from inside of machine. Drain automatically closed by lowering inspection door. Drain seal is large diameter, high temperature o-ring. Stainless steel drain seat. Drain casting can be plumbed from load or unload end of machine.

STANDARD EQUIPMENT: Sealed dial-type thermometers indicate temperatures of wash and final rinse water. Positive low water protection for tank heat. Plastic strip curtains throughout machine. Stainless steel control box. Built-in wireway. Drain is automatically closed when inspection door is closed. Stainless steel adjustable feet. Stainless steel hang-on/drop-in-place front trim panel. Automatic tank fill. Door interlock. Auto-timer. Vent fan and booster heater controls.

OPTIONAL EQUIPMENT AT EXTRA COST: WASH TANK HEATING

ELECTRIC: One electric incoloy sheathed immersion heater (15 KW) removable from inside tank. Tank water temperature is controlled by solid-state thermostat with positive low-water protection and magnetic contactor. (Disconnect switches not furnished.) Heating element is additionally protected by a high limit device mounted on the surface of the element.

STEAM: One-inch stainless steel steam injector or one-inch stainless steel steam coils (for contaminated steam). Tank water temperature controlled by solid-state thermostat with positive low-water protection. Steam supplied to machine through high temperature steam solenoid valve and line strainer.

GAS: Regulated power immersion tube gas burner system. Tank water temperature is controlled by solid-state thermostat and a blower with a centrifugal switch. Positive low water protection is provided. Immersion tube is additionally protected by a high limit device mounted on the surface of the tube. A solid-state ignitor board controls the gas valve and provides flame ignition.

A transformer steps the control circuit voltage down from 120 volts to 24 volts to power the ignitor board and gas valve.

For natural gas, gas pressure to burner (customer connection) not to exceed 7" W.C.

For LP gas, gas pressure to burner (customer connection) not to exceed 11" W.C.

If gas pressure is higher than 7" W.C. natural or 11" W.C. LP, a pressure regulating valve must be supplied (by others) in the gas line to the dishwasher.

OPTIONAL EQUIPMENT AT EXTRA COST:

Stainless steel pressureless booster heater. Stainless steel vent hoods with vent stack and locking-type damper. Stainless steel extended hoods with vent stack and locking type damper. SL-23 and SL-30 side loaders without hood. Six inches higher than standard. Steam or electric blower dryer (3-phase only). Floor-mounted steam booster. 19 $\frac{3}{4}$ " x 19 $\frac{3}{4}$ " peg and combination and miscellaneous racks.

Single-point electrical connection for electric heat machines (3-phase only, does not include booster heater). Conveyor dwell. Table limit switch.

As continued product improvement is a policy of Hobart, specifications are subject to change without notice.